

PCK43304W

433MHz PentaCODE[®] Transmitter with 4 External Inputs

Features

- Four external inputs (voltage free)
- Compatible with all PCR Penta series receivers
- 12 to 24 Volts AC/DC supply or 12 Volt battery
- Frequency hopping between 433.100 to 434.700 MHz
- Easy coding with 12-way dipswitch or encrypted coding



Applications

Wireless Push Button, Industrial Controls, Duress button, Security, PLC controlled transmitter or to reduce the need to run control wires over a long distance.

Description

This easy-to-install transmitter combines 4 inputs, long range, frequency hopping and different transmission modes into a single small device. This transmitter is a fixed high power transmitter compatible with the Penta (PCR series) receivers.

With the frequency hopping, the transmitter allows multiple systems to be used in one area with no interference. The transmitter modes are user selectable and adjustable timing is set with an on board trimpot. LED indicates an input is activated.

Installation is easy with pluggable terminal blocks for the supply and inputs. The transmitter comes with a short range micro antenna which can be replaced with an Elsema ANT433S antenna to get an operating range of 500 metres.

Technical Data

Supply Voltage	12 to 24 Volts AC or DC
Standby Current	6uA standby at 12 Volts DC. (Suitable for battery operation)
Current Consumption	27mA when transmitting
Frequency Band	433.100 to 434.700 MHz
Operating Range	500 metres with ANT433S antenna
Number of Inputs	4 dry contacts, optically isolated
Connections	Screw type terminal block. See block diagram
Dimensions	90mm x 50mm x 25mm
Weight	70 grams
Useable Receivers	All 433MHz Penta series

Block Diagram

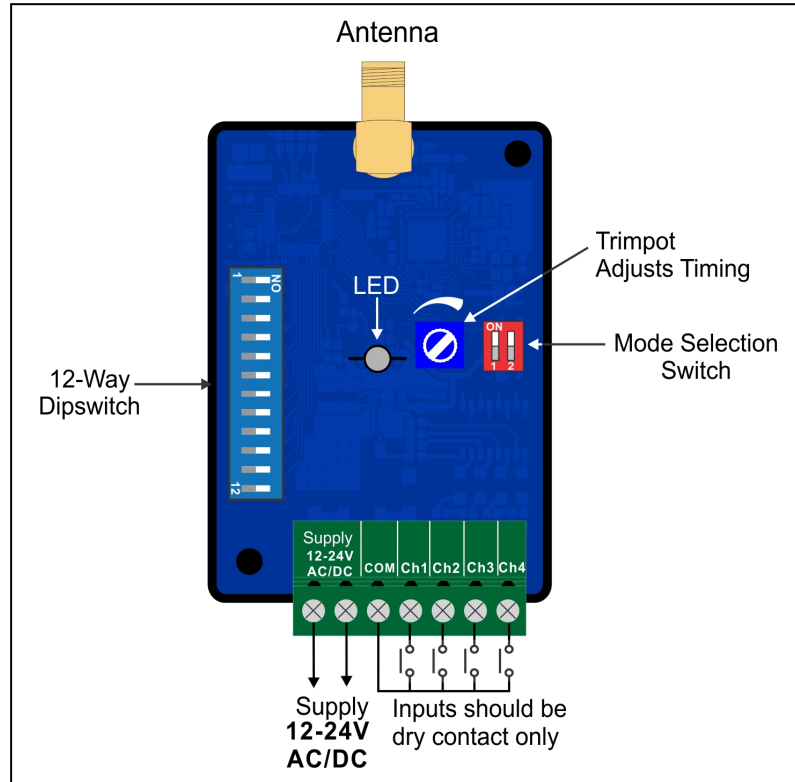

Inputs of the transmitter should be voltage free contact closure only.

Transmitter Modes

	<p><i>Off Delay 2 – 62 seconds</i> Transmitter will transmit a 1.5 second transmission burst and then stop for the "off delay" time selected. The "off delay" time is user selectable between 2 to 62 seconds by adjusting trimpot on the transmitter board. If the inputs change during the "off delay" period, the new code will be transmitted immediately. When the "off delay" time lapses, transmitter will transmit another burst. The transmitter will cycle (transmission and off delay) indefinitely, if at least one input is ON and supply is connected.</p>
	<p><i>Reserved</i></p>
	<p><i>Continuous Transmission*</i> Transmitter will transmit continuously, if at least one input is activated and supply is connected. A transmission limit of five minutes is used to comply with local radio regulations. To activate a receiver longer than 5 minutes, use a delay off feature in the receiver and transmitter. The delay off feature in the receiver needs to be set <u>more</u> than the transmitter. This ensures that the transmitter keeps resetting the off delay in the receiver.</p>
	<p><i>1.5 – 10 seconds one burst transmission</i> Transmitter will transmit one burst and then go to standby or sleep mode. Adjusting the trimpot will vary the burst length. When the input is changed and supply is connected, transmitter will transmit one new burst of the new code.</p>
<p>Sleep mode (6 uA) is activated when all inputs are OFF; this applies to all four modes</p>	

(Grey illustrates the position of the DIP switches)

*Refer to the website for further details. <https://www.elsema.com/contitran.htm>

PentaCODE[®] Programming Instructions

12- Way Dip Switch Coding

1. Set a random code on the receiver dip switch by flicking the dip switches "On" or "Off".
(DO NOT USE THE DEFAULT FACTORY SETTING FOR THE 12-WAY DIP SWITCH AS THIS IS A COMMON CODE)
2. Open the cover of the PentaCODE[®] transmitter.
3. Match the 12-way dip switch to the receivers 12-way dip switch.
4. Activate channel 1 on the transmitter and the receiver output should activate. This is indicated by the receiver LED.

To program the same PentaCODE[®] transmitter channels 2, 3 or 4 to another receiver change dip switch 11 and 12 in the 2nd, 3rd and 4th receivers. For example:

	Receivers Dip Switch 11	Receiver Dip Switch 12
Receiver 1	Off	Off
Receiver 2	On	Off
Receiver 3	Off	On
Receiver 4	On	On

Dip switches 1 to 10 should all be the same in the transmitter and the receivers.

Encrypted Coding - (All 12-Way Dip Switches must be "Off")

Coding the PentaCODE[®] transmitter and receivers can be done in 3 different ways.

1. Receiver to a transmitter
 2. Transmitter to a Receiver
 3. Transmitter to another transmitter
- Receiver to a transmitter
1. Press and hold the program button 1 on the receiver.
 2. Activate channel 1 of the transmitter for 2 seconds, receiver LED will flash Green
 3. Deactivate channel 1 of the transmitter then release the receiver program button.
 4. The LED on the PentaCODE[®] transmitter will flash to confirm the coding has been successful.
- Transmitter to a Receiver / transmitter to another transmitter
- Set one of the transmitter or receiver to broadcast its code. The broadcaster's code will be programmed to the other units.
- To broadcast the transmitters code, make sure all 12 dip switches are "off". Then activate channel 1 and flick dip switch 12 "on" and then "off". This is confirmed by the LED being "on" for 10 seconds. You can release channel 1.
 - To broadcast the receivers code, make sure all 12 dip switches are "off" and then flick dip switch 12 "on" and then "off". This is confirmed by the green LED being on for 10 seconds.
- While broadcasting the code, activate channel 1 on a different transmitter or receiver for 1 second and then release the input. The LED will flash twice to confirm successful programming.

Broadcasting will be latched on for 10 seconds or stop if any dipswitch is turned on.

Deleting Receivers Memory

Short the CC pin on the receiver for 10 seconds. **This will delete all the transmitters from the receiver's memory.**